

stormwater management for clean rivers

How to manage stormwater

Downspout Disconnection

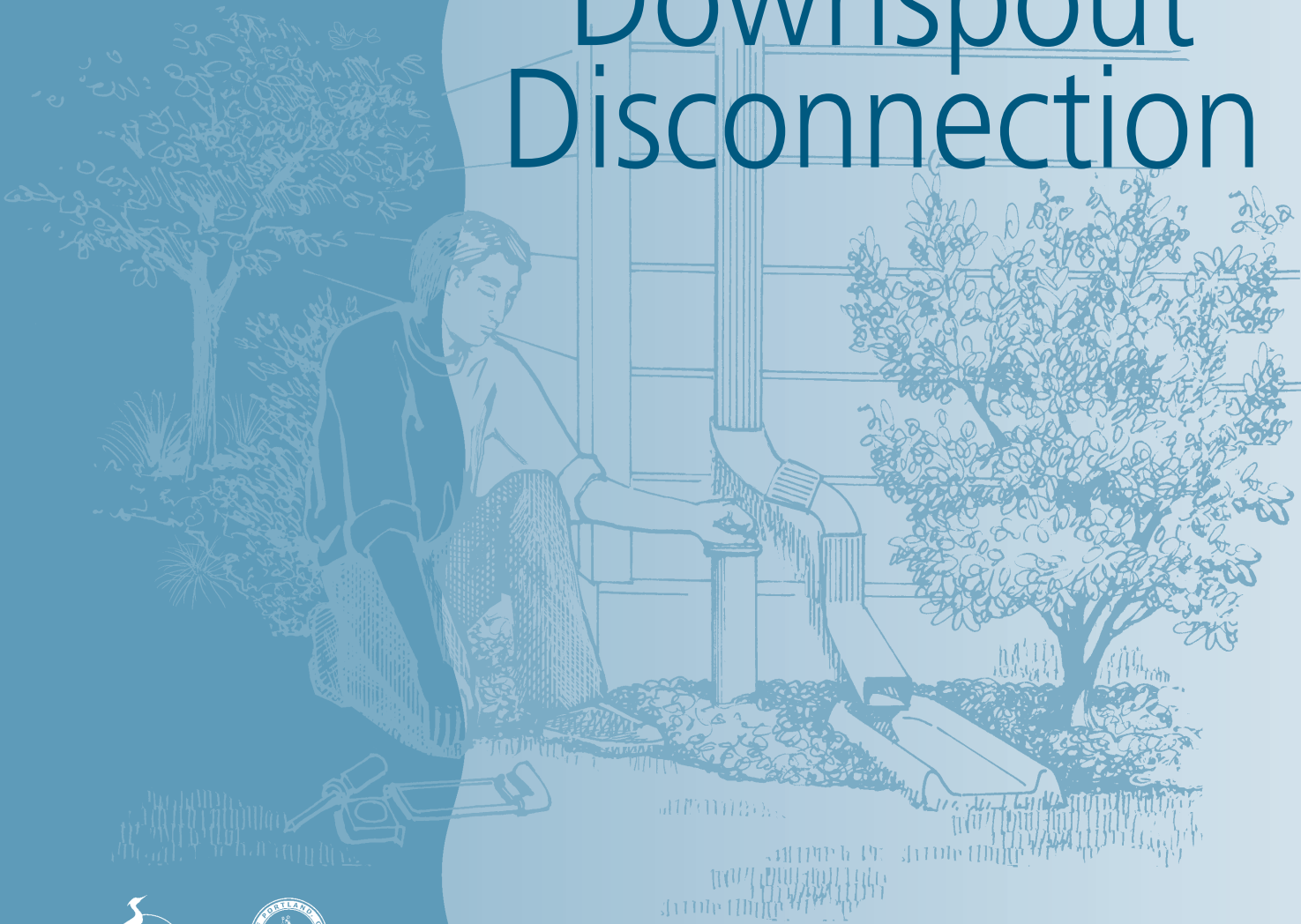

ENVIRONMENTAL SERVICES
CITY OF PORTLAND

working for clean rivers

how to disconnect downspouts

Portland gets an average of 37 inches of rain a year. Rain that runs off your roof can flow directly into a sewer pipe, stream or groundwater. Why not put it to better use? You can disconnect your downspouts to redirect water to your yard or garden. Containing rainwater from hard surfaces on your property also reduces demand on the sewer system and protects the quality of rivers, streams, and groundwater.

What is involved in disconnecting my downspouts?

You can disconnect your downspouts from existing standpipes and let it flow over landscaped areas or lawns. Disconnection can be a low-maintenance option to help move water away from building foundations and allow it to soak into the ground. Disconnecting includes cutting the downspout; attaching elbows, extensions, and splashblocks to direct the water to flow away from the house; plugging the standpipe; and securing the materials to existing structures.

Other brochures in this series show you *How to* build a rain garden, soakage trench, or rain barrel, to manage the stormwater runoff. Refer to the resources section on page 7 to learn how to get copies.

Are there incentives?

When you contain the rain on your property, you qualify for a discount on the stormwater portion of your city utility bill. See the resources section of this brochure for more information on *Clean River Rewards*.

If you live in the Downspout Disconnection Program area, you can have your downspouts disconnected for free or you can earn \$53 for each downspout disconnected that meets the safety considerations on page 3. Over 58,000 homeowners

have disconnected downspouts to help reduce combined sewer overflows (CSOs) to the Columbia Slough and Willamette River. See the resources section of this brochure for more information on this special target area.

Where do I start?

Begin by preparing a good plan to ensure that the stormwater soaks into the ground without damaging your structures or neighboring structures. This brochure describes a simple, four-step process to help you disconnect your downspouts.

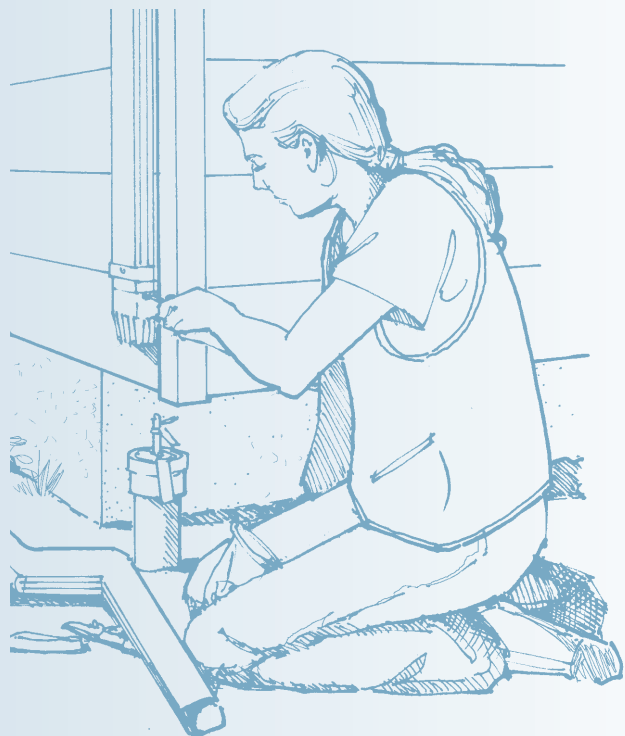

1 observe your site



Find out where runoff from your downspouts goes, including your house, garage, and other covered surfaces. Are your downspouts draining to your lawn or are they connected to the sewer system or to drywells? Downspouts that drain into standpipes (pipes) may drain into a public sewer system, a curb cut (a hole in the curb at the sidewalk), soakage trench, a drywell, or other stormwater drainage system. If your downspouts drain into soakage trenches or drywells on your property and are in good working order, you do not need to disconnect, but may want to in order to avoid future maintenance or replacement costs.

To find out if you have soakage trenches or drywells, call 503-823-7660 for plumbing permits or building records on file for your property.

Draw what you see

Sketch a site plan. You can print an aerial view of your property from PortlandMaps.com as a starting point.

Mark the locations of downspouts and roof line and estimate the square footage of your roof area. Map out areas in your yard down slope of structures where you might disconnect downspouts.

example site plan: locate existing downspouts

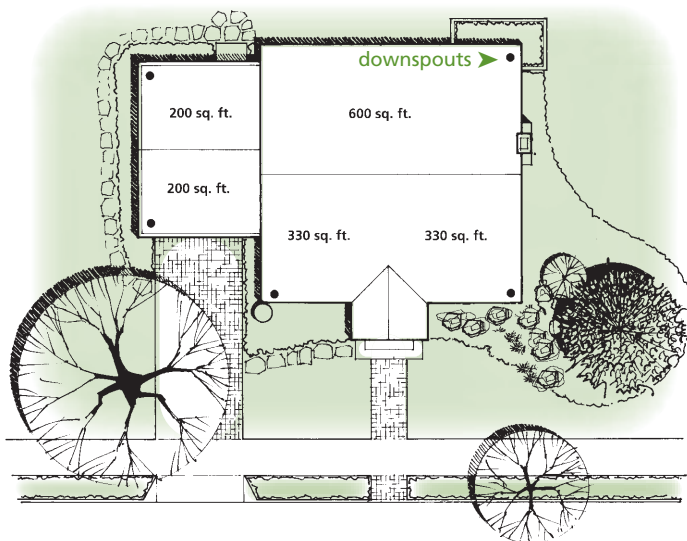

Safety considerations

Slope: Add or remove soil to make sure that the slope of the ground allows water to flow away from structures. However, do not disconnect downspouts on slopes over 10%.

Drainage: Avoid disconnecting downspouts in an area too small for good drainage (see page 4 for guidelines).

Extensions: Disconnected downspouts must be extended to discharge water at least 6 feet from a structure's basement and 2 feet from a structure's crawl space or slab foundation. Downspout extensions and surrounding landscape surface must drain water away from any structures.

Property Lines: The end of your downspout extension must be at least 5 feet from your neighbors' property line and 3 feet from the public sidewalk. You may need more room if your yard slopes towards your neighbor or the sidewalk.

Access: Avoid disconnecting downspouts or adding downspout extensions across a walkway, patio, driveway, or in front of a gate because of possible tripping hazards.

Other Hazards: Do not disconnect directly over a septic system, drain field, or an underground oil tank unless they have been decommissioned. Do not disconnect within ten feet of a retaining wall.

2 design your disconnection

Mark downspouts to be disconnected on your existing site plan. Mark where you might pitch gutters, move downspouts, remove walkways or other impervious areas, or add extensions or elbows to get around plants or other obstructions.

Make sure you have enough landscaped area for rain to soak safely into the ground. The ground area must be at least 10% of the roof area that drains to the disconnected downspout.

For example, to drain 500 square feet of rooftop, there should be at least 50 square feet of landscape.

roof area **sizing factor** **landscaped area size**
500 sq. ft. x 10% = 50 sq. ft. (or 5' x 10')

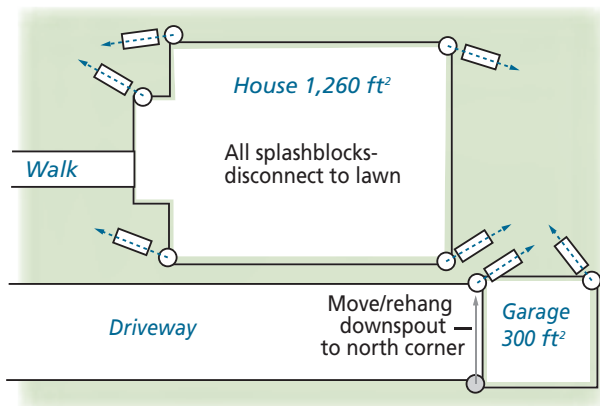

You may have more than one option for directing each downspout. Consider combining elbows and extensions to send water to the side or front, or to get around obstacles and drain water away from the house. Downspouts can also be relocated along the gutter to a safe drainage location.

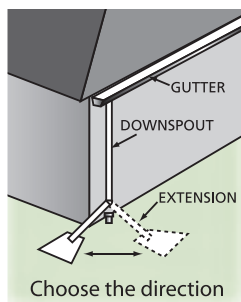

Tools

You will need a hacksaw, a drill, a pair of needle-nose pliers or crimpers, a tape measure, and a screwdriver or nut driver.

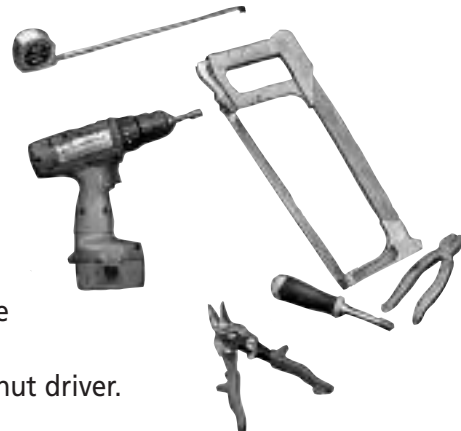

Materials

Make a list of the parts and materials needed. Downspout elbows and extensions come in a few standard shapes, sizes, colors, and materials to fit your gutters. Ask if the materials you choose can be painted to match your paint color or blend into your landscaping. Sewer standpipes must be sealed with a rubber cap secured by a hose clamp or with a wing-nut test plug. Most standpipes are between three and five inches wide. Measure the inside diameter of yours before shopping.

Some downspouts are attached only to the gutter and the sewer standpipe. If so, you may need to secure your downspout to your house with a bracket or strap to keep it in place when you disconnect.

Use durable, gutter-grade materials such as aluminum, steel, copper, vinyl, and plastic. Black ABS SCH 40 plastic is a durable option found in most hardware stores and home centers. **Do NOT use** corrugated black plastic (ADS), roll-out-hose, PVC pipe, dryer hose, swivel or open-trough materials because of their limited durability.



Other suggestions

- 1 Consider installing a hinged downspout elbow and enclosed extension that you can flip up against the house during dry weather or lawn mowing. The extension must be enclosed, not an open trough. (see diagram 1)
- 2 Think about creating a space to disconnect by removing paved surfaces, such as concrete pathways, patios or unused driveway area.
- 3 Replace pavement or concrete with pavers or gravel where appropriate to allow for infiltration. (see diagram 3)
- 4 Extend downspouts underneath a deck or raised patio to get runoff to a landscaped area. (see diagram 4)
- 5 Use plastic or concrete splashblocks, rocks, flagstone, or boulders at the end of downspouts to control erosion, help direct runoff, and add visual interest. (see diagram 5)
- 6 Incorporate other stormwater management systems into your downspout disconnections, such as a rain garden, soakage trench, or rainwater harvesting system. See the resources section for more information.

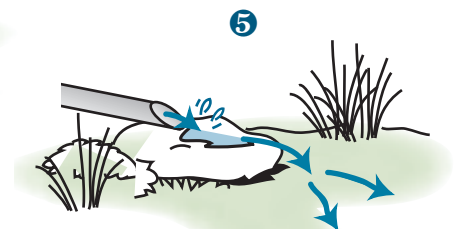
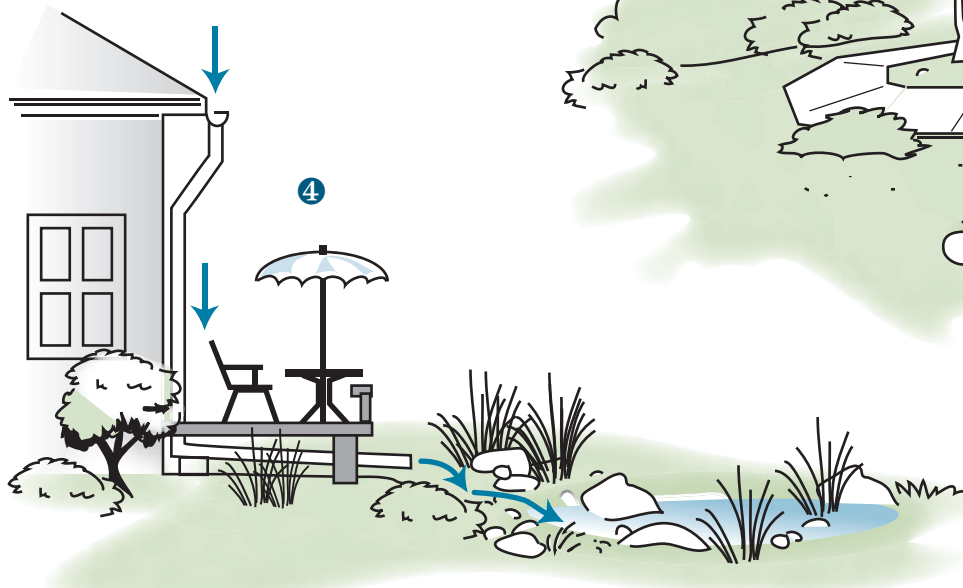
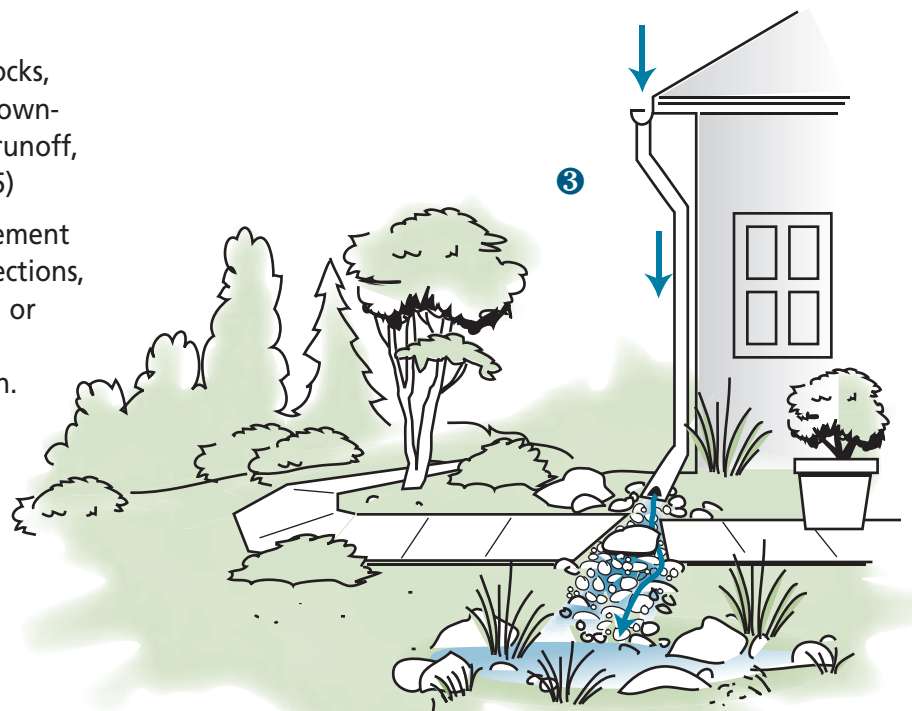

3 disconnect

All disconnections should meet the safety considerations found on page 3 and the water should flow away from all structures.

- A Measure the existing downspout** from the top of the standpipe and mark it at about 9 inches above the standpipe. You may need to cut the downspout higher depending on the length of your extension.
- B Cut the existing downspout** with a hacksaw at the mark. Remove the cut piece.
- C Plug or cap the standpipe** using an in-pipe test plug or an over-the-pipe cap secured by a hose clamp. Do NOT use concrete to seal your standpipe.
- D Attach the elbow.** Be sure to attach the elbow OVER the downspout. Do NOT insert the elbow up inside the downspout or it will leak. If the elbow does not fit over the downspout, use crimpers or needle-nose pliers to crimp the end of the cut downspout so it slides INSIDE the elbow.
- E Measure and cut the downspout extension** to the desired length. Attach the extension to the elbow by slipping the extension OVER the end of the elbow. Do NOT install the elbow over the extension or it will leak. The length of the extension will depend on site conditions and where you want the downspout to drain.
 - Downspouts must drain at least 6 feet from basement walls and at least 2 feet from crawl spaces and concrete slabs.
 - The end of the downspout must be at least 5 feet from your property line, and possibly more if your yard slopes toward your neighbor's house.
- F Secure the pieces** with sheet metal screws at each joint where the downspout, elbow, and extension connect. It helps to pre-drill holes for the screws.
- G Using a splash block** at the end of the extension is optional, but it will help prevent soil erosion.

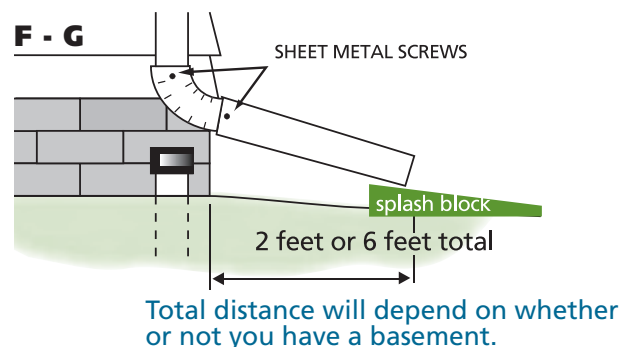
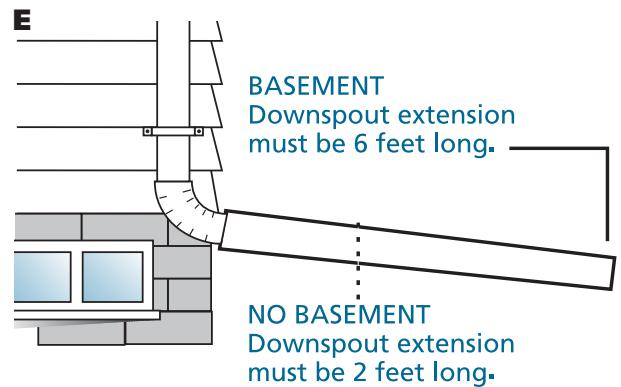
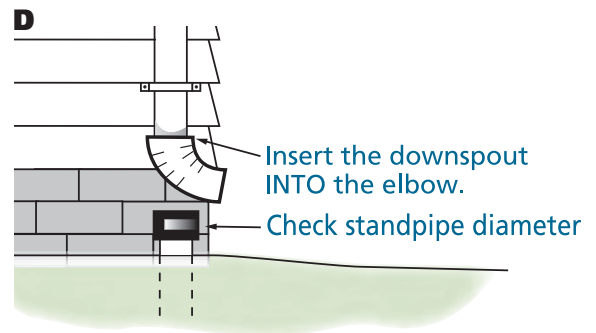
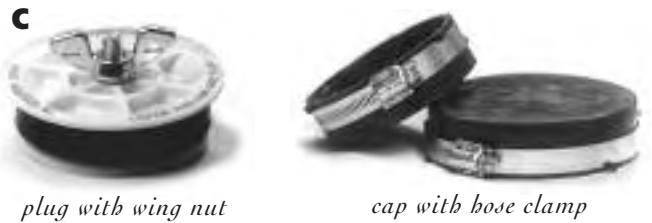
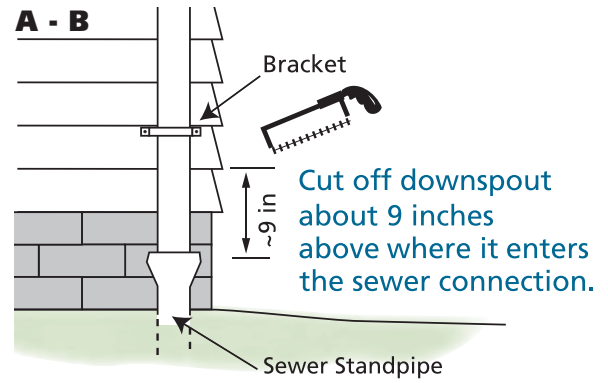

4 maintenance

Proper maintenance of your gutters, downspouts, and landscaping can reduce problems.

Gutters:

- Clean at least twice a year, and more often if you have overhanging trees.
- Make sure gutters are pitched to direct water to downspouts.
- Caulk leaks and holes.
- Make sure roof flashing directs water into the gutters.
- Look for low spots or sagging areas along the gutter line and repair with spikes or place new hangers as needed.



Downspouts:

- Check and clear elbows or bends in downspouts to prevent clogging.
- Each elbow or section of the downspout should funnel into the one below it. All parts should be securely fastened together with sheet metal screws.

Landscaping:

- The ground should slope away from structures.
- Don't build up soil, bark dust, or woodpiles against the siding.
- Avoid draining water onto impermeable plastic weed block or cloth.

resources

Clean River Rewards

Clean River Rewards is Portland's stormwater discount program. When you contain the rain safely on your property, you can save money with an ongoing discount on your city utility bill. Go to www.CleanRiverRewards.com to register or to download publications to help you plan, build and maintain disconnected downspouts or other stormwater management options. You can also find other technical assistance information and useful links. For more information, call 503-823-1371.

Downspout Disconnection Program

The city offers free disconnection work for homes in the Downspout Disconnection Program target area, or homeowners in the target area can earn a one-time incentive of \$53 per downspout disconnected that meets the safety considerations on page 3. For more program information call 503-823-5858 or visit www.portlandonline.com/downspoutdisconnect.

Download all the **How to** brochures at www.CleanRiverRewards.com

Additional Information

City of Portland Stormwater Management Manual: www.portlandonline.com/bes/index.cfm?c=35117

City of Portland Stormwater Solutions Handbook: www.portlandonline.com/bes/index.cfm?c=43110



Environmental Services
Sam Adams, Commissioner
Dean Marriott, Director

1120 SW Fifth Avenue
Portland Oregon, 97204

503-823-7740
www.cleanriverspdx.org

Other publications in this brochure series:
How to manage stormwater - Rain Gardens
How to manage stormwater - Soakage Trenches
How to manage stormwater - Rain Barrels

To help ensure equal access to city programs, services, and activities, the city will reasonably accommodate persons with disabilities. Call 503-823-7740 or 1-800-735-2900 with such requests. TDD 503-823-6868.